

# H7 PLASMA XENON 5000K



## Product Description

Intense, bright and white light similar to Xenon HID bulbs - up to 90% more light on the road. One of the brightest bulbs, provide maximum visibility and safety in all conditions. Ideal off-road bulbs with Max Blue Halogen Effect - Up to + 40m more distance.

- Up to + 90% more light
- Up to + 40 m more distance
- Max Blue Xenon Effect
- No ECE confirmation / E-Mark – only off-road use

Lunex halogen bulbs produce up to two times more luminous power than standard bulbs, thereby improving driving safety in all conditions, provide maximum visibility. They last far longer than standard bulbs. The light they provide is more intense and offers a consistent, clearly defined beam.

Unique patented packaging to ensure reliability of the product transport as per picture above.

UV filter – extended the lifetime of bulbs - increase the life span.

HQ UV Quartz Glass is a very strong glass, resistant to extreme temperatures and vibrations, eliminating the risk of explosion. UV quartz glass emits a stronger, cleaner light.

Simple to use, no need to change the lamp line and easy installation (plug in & replace stock light bulbs).

Authenticity confirmation - QR code

International warranty - 1 year

High Quality Premium Replacement Bulbs

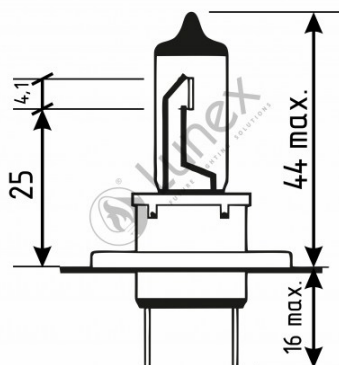

## Technical data

Power input	55 W
Nominal voltage	12.0 V
Nominal wattage	55 W
Base	PX26d
Color temperature	5000K
Luminous flux	1500 lm